

GERRESHEIMER



High-Quality Pharmaceutical Plastic Packaging and Systems for Solid Dosages



www.gerresheimer.com

Gerresheimer Plastic Packaging

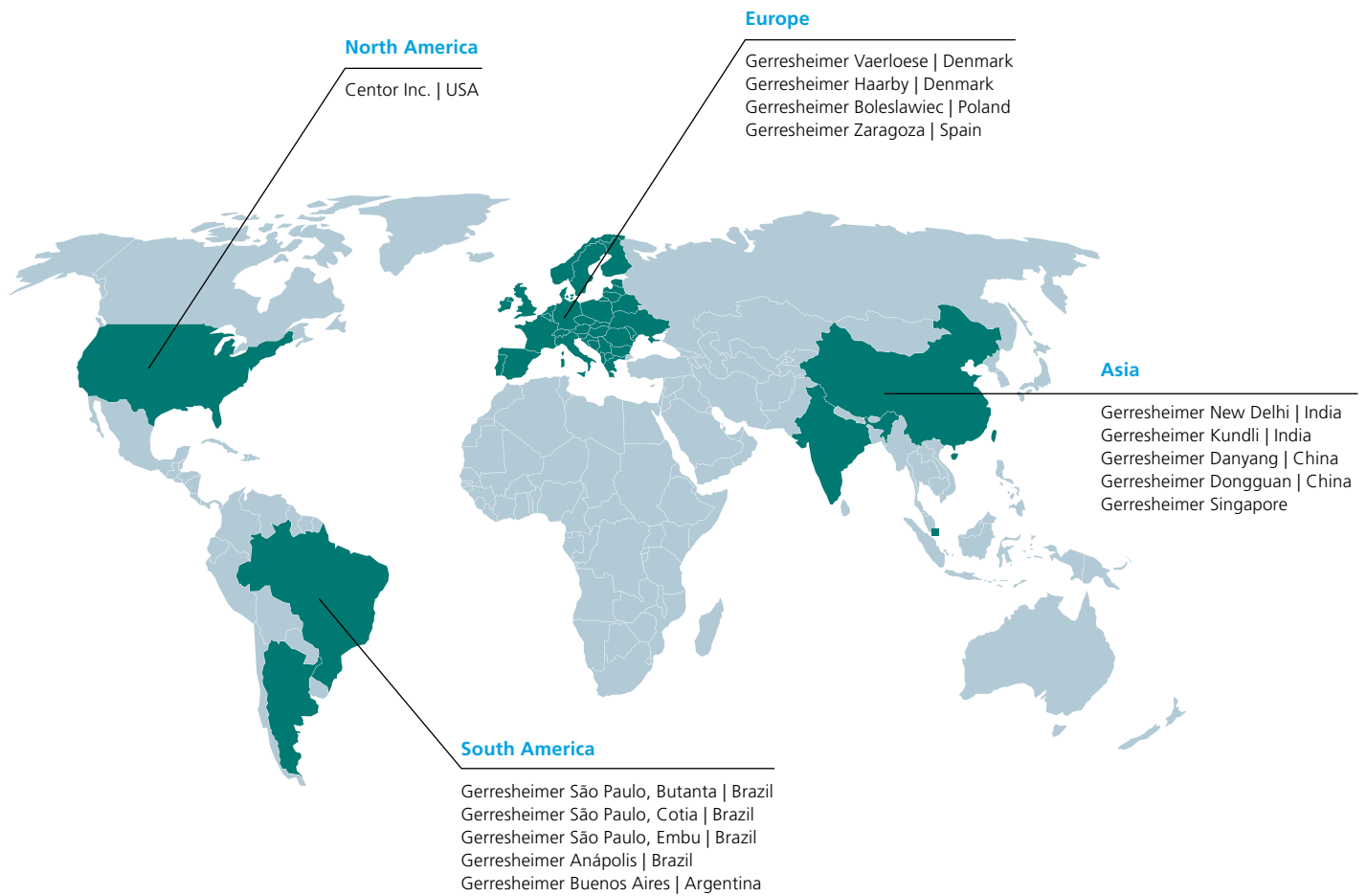

About Gerresheimer

Gerresheimer is a leading global partner to the pharma and health-care industry. With our specialty glass and plastic products, we contribute to health and well-being. We have worldwide operations and about 10,000 employees manufacture our products in local markets, close to our customers. With our plants in Europe, North America, South America and Asia, we generate revenues of approximately EUR 1.4 billion.

The comprehensive product portfolio includes pharmaceutical packaging and products for the safe, simple administration of medicines: Insulin pens, inhalers, prefilled syringes, injection vials, ampoules, bottles and containers for liquid and solid medicines with closure and safety systems as well as packaging for the cosmetics industry.

Gerresheimer Plastic Packaging Solutions

Intelligent products for diverse pharmaceutical applications



PET / Liquid & Solid



Ophthalmic, Nasal and Parenteral Applications



Solid Dosages

Gerresheimer Plastic Packaging specializes in the widely varied spectrum of pharmaceutical plastic packaging within solid, liquid and ophthalmic applications, plastic vials and plastic bottles for personal care. Our leading brands Duma®, Dudek™ and Triveni for solid dosage, edp-branded PET bottles for liquid dosage and our ophthalmic products form part of a comprehensive and innovative product range. Our plastic vials branded MultiShell® are specially designed for sensitive parenteral drug formulations.

Our standard range includes a wide choice of different types of containers and closures, PET bottles, eye droppers, nasal sprays, nebulisers as well as numerous customized developments.

Using our ideas and experience to produce intelligent, increasingly safe and user-friendly packaging solutions has enabled us to become an innovative partner to the global pharmaceutical industry.

We know, understand and reinforce our customers business.

Specialist and quality leader in primary plastic packaging

Our manufacturing operations use state-of-the-art technology and apply the most rigorous quality and hygiene standards. They cover all production technologies from injection moulding and injection blow moulding to blow moulding processes. The majority of our production operations are carried out in modern classified clean-rooms or in clean conditions. All plants apply the rules of Good Manufacturing Practice (GMP) and are certified in accordance with ISO standards.

- Solution providing
- Good Manufacturing Practice (GMP)
- ISO certifications (ISO 9001, ISO 15378, ISO 14001)
- Automated in-line controls
- Vision-based inspection system
- Class 7 (10,000) + class 8 (100,000) clean-rooms

Strong regulatory approach

We ensure full conformity of our products with the European pharmacopoeia, the United States pharmacopeia and the requirements for FDA registration with a Drug Master File as the standard. Knowing the extensive requirements of our customers we focus on providing a high level of documentation with our products.

- High level of documentation and registration
- Standard product database
- FDA and world-wide registration of all products
- US and Canada Drug Master File
- Product registrations in Russia, China and the Ukraine
- Food approval

Strong quality culture

A strong quality culture supports our efforts to deliver excellent quality. The culture is defined by our shared beliefs, values and behaviour patterns.

- Quality attitude and team work
- Continuous improvements
- Systematic problem solving
- Quality by design
- Stable, robust, reliable and validated processes
- Risk-based approach

Innovative and trendsetting

Dedication to technological advancement and product development enable Gerresheimer to set benchmarks in packaging design. We offer our pharmaceutical customers the very latest developments in packaging systems.

- Longer shelf-life requirements for sensitive pharmaceutical formulations
- Higher compliance standards
- Child-resistant and senior-friendly closure systems
- Total solution provider
- Barrier packaging
- Unique, customized solutions for niche market segments

For our ophthalmic range we developed the DropAid, which can be used by people in all ages and with this device you ensure easy, precise and correct medication



DROPAID

The double TE-function consist of both the tamper-evident ring and a liner



DUMA TWIST-OFF DOUBLE TE-CLOSURE

We have launched an eco-friendly plastic packaging solution called BioPack and our customers hereby contribute to the reduction of greenhouse gas emissions by protecting the environment and avoid unnecessary waste



BIOPACK

Duma Pocket now also available in 100 ml with integrated cap with dispensing hole and child-resistant feature



DUMA POCKET

Duma Twist-Off Protect capability extended to our US container

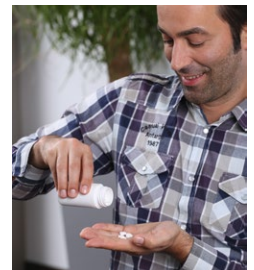

US CONTAINER WITH PROTECT FEATURES

2015 2016 MORE

DUMA TWIST-OFF PROTECT



The unique Duma Twist-Off Protect container offers with the multilayer a significantly improved protection against water vapor and oxygen

DUMA TWIST-OFF CR/SF



Development of the second generation of the Duma Twist-Off CR/SF closure

DUMA COMBI



Packaging and patient information has been integrated in the Duma Combi

TE-RING ON DROPPER BOTTLES



Dropper bottle system A now with a blocked TE-ring on the bottle. All dimensions, properties and material are kept the same

Solid applications



Our Duma®, Dudek™ and Triveni branded products include a broad range of containers in HDPE and caps in LDPE & PP for the pharmaceutical market.

A wide choice of solid dosage, closure and security systems makes the range fully adaptable to the individual requirements of the customer.

Our assortment includes screw cap containers, snap-on containers and closures with child-resistant and senior-friendly features.

- Screw cap containers
- Snap-on containers
- Special designs
- Containers in HDPE
- Caps and closures in LDPE & PP
- Tight container and closure fit
- Child-resistant and senior-friendly closures
- Duma® OneLiner®
- Available with different desiccant sizes (integrated / mounted) and adsorbents
- FDA registered, DMF type III, DMF no. 12077, DMF no. 11711 for containers, DMF no. 22377 for CT closures
- Tamper-evident

Solid containers

... with screw system (TE + CR + SF)

- 1**



Duma®
Twist-Off
- 2**



Duma®
Twist-Off Q
- 3**



Duma®
MG/Multi-Grip
- 4**



Europe Seal
(induction seal)
- 5**



Triveni Round /
Triveni Square
(induction seal)
- 6**



Triveni Dry Syrup
(induction seal)
- 7**



Triveni Black Lining
(induction seal)

... with snap-on system (TE + CR)

- 8**



Duma®
Standard
- 9**



Duma®
Special
- 10**



Dudek™
- 11**



Duma®
Rectangular

Special design

- 12**



Duma®
Pocket
- 

Duma® Twist-Off



SPECIFICATIONS

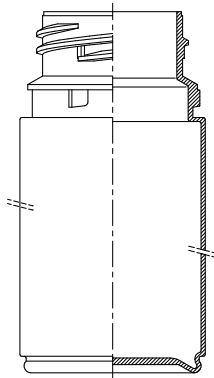
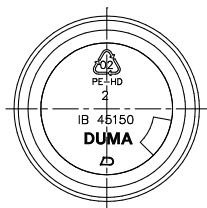

TE*

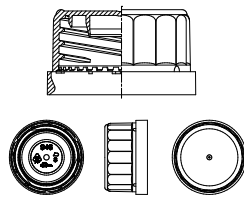

TE*



TE/Int. Des.**



TE/CR***

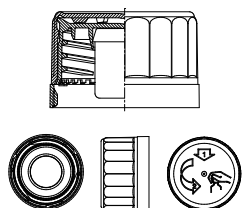

TE/CR***



TE/CR/SF****



Duma® Twist-Off

ref	ml	mm	mm	mm	Label mm	ref TE*	ref TE/Int. Des.**	ref TE/CR***	TE/CR/SF****
35015	15	36	46	21	14	2827	2827	2829	–
35030	30	36	61	21	29	2827	2827	2829	–
45035	35	45	51	31	18	3827	3827	3829	3833
35040	40	36	68	21	36	2827	2827	2829	–
35050	50	36	83	21	51	2827	2827	2829	–
45060	60	45	64	31	31	3827	3827	3829	3833
45075	75	45	79	31	46	3827	3827	3829	3833
45100	100	45	96	31	63	3827	3827	3829	3833
45106	100	60	83	31	41	3827	3827	3829	3833
45125	125	45	107	31	74	3827	3827	3829	3833
45150	150	45	133	31	100	3827	3827	3829	3833
45156	150	60	102	31	60	3827	3827	3829	3833
45206	200	60	121	31	79	3827	3827	3829	3833
45256	250	60	140	31	97	3827	3827	3829	3833
45306	300	60	158	31	116	3827	3827	3829	3833
45406	400	60	193	31	150	3827	3827	3829	3833
45407	400	75	139	31	90	3827	3827	3829	3833
45607	600	75	188	31	138	3827	3827	3829	3833

*TE – tamper-evident with break-away ring or liner (OneLiner®) / **Int. Des. – integrated desiccant / ***CR – child-resistant / ****SF – senior-friendly

- Material: container HDPE, closure PP
- 18 Twist-Off sizes ranging from 15–600 ml
- Twist-Off cap system
- Available with integrated and mounted desiccant 0.5–6 gr.
- FDA registered, DMF type III, DMF no. 12077
- Tamper-evident
- Available as child-resistant
- Available with senior-friendly closure, with child-resistance
- Containers produced by injection blow moulding/blow moulding
- Closures produced by injection moulding
- Manufactured under clean-room conditions
- Some container sizes are available with a thick wall
- Available with Duma® OneLiner® for the US market

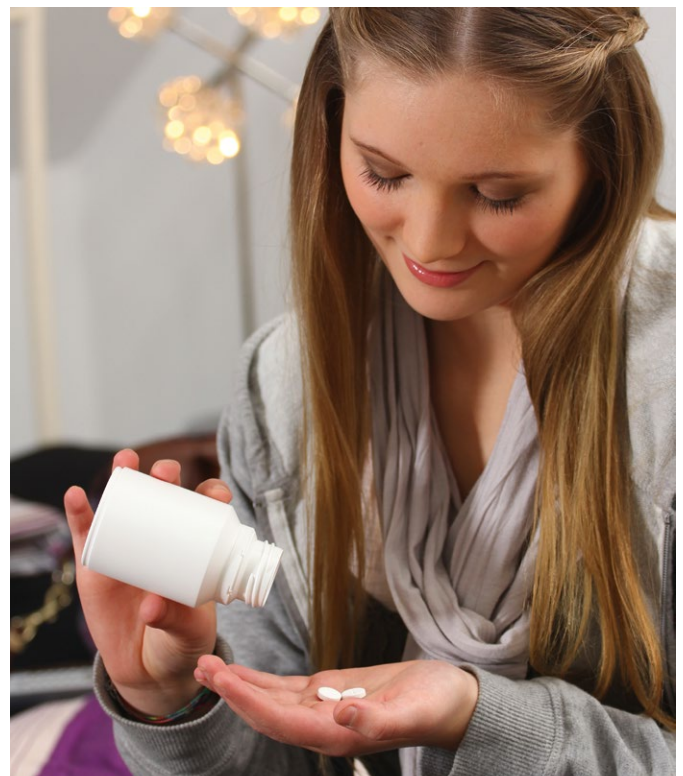

Duma® Twist-Off Q



SPECIFICATIONS

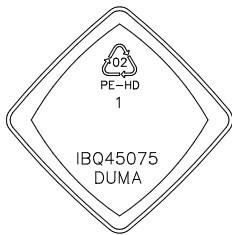

TE*

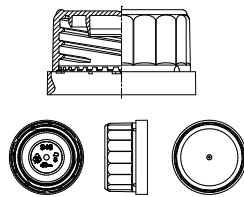

TE*



TE/Int. Des.**

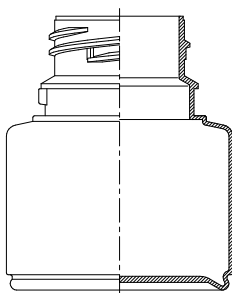

TE/CR***

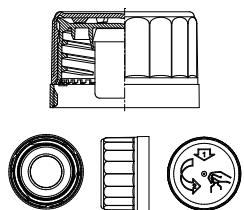

TE/CR***



TE/CR/SF****



Duma® Twist-Off Q

ref	ml	mm	mm	mm	Label mm	ref TE*	ref TE/Int. Des.**	ref TE/CR***	TE/CR/SF****
Q35030	30	37	57	21	24	2827	2827	2829	–
Q35040	40	37	66	21	33	2827	2827	2829	–
Q35050	50	37	75	21	41	2827	2827	2829	–
Q45075	75	46	72	31	38	3827	3827	3829	3833
Q45100	100	46	87	31	52	3827	3827	3829	3833
Q45150	150	46	113	31	78	3827	3827	3829	3833
Q45200	200	46	140	31	105	3827	3827	3829	3833

*TE – tamper-evident with break-away ring or liner (OneLiner®) / **Int. Des. – integrated desiccant / ***CR – child-resistant / ****SF – senior-friendly

- Material: container HDPE, closure PP
- 7 Twist-Off Q sizes ranging from 30–200 ml
- Twist-Off cap system
- Available with integrated and mounted desiccant 0.5–6 gr.
- FDA registered, DMF type III, DMF no. 12077
- Tamper-evident
- Available with child-resistant closure
- Available with senior-friendly closure, with and without child-resistance
- Containers produced by injection blow moulding/blow moulding
- Closures produced by injection moulding
- Manufactured under clean-room conditions
- Duma® OneLiner®



Duma® MG / Duma® Multi-Grip



SPECIFICATIONS

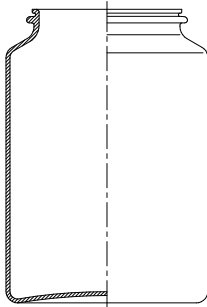
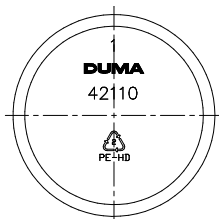

Duma® MG

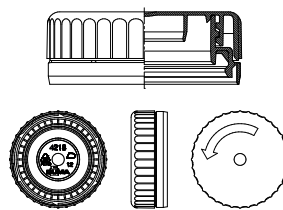



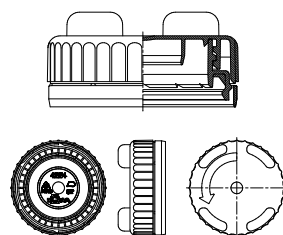





Duma® Multi-Grip





Duma® MG / Duma® Multi-Grip

							
34040	40	44	49	27	27	3418	3424
34050	50	44	57	27	34	3418	3424
34075	75	44	76	27	52	3418	3424
42110	110	52	75	35	50	4218	4224
42150	150	52	97	35	70	4218	4224
42200	200	64	91	35	63	4218	4224
42275	275	64	113	35	78	4218	4224

*TE – tamper-evident with break-away ring / **SF – senior-friendly

- Material: container HDPE, redesigned cap and adapter HDPE
- 7 sizes ranging from 40–275 ml
- Screw cap system
- Narrow and wide neck design
- Available with desiccant mount 0.5–2 gr.
- FDA registered, DMF type III, DMF no. 12077
- Cap and adapter are delivered assembled
- New redesigned Duma® MG cap

- Duma® Multi-Grip – easy access for users with limited dexterity
- Visible tamper-evident ring
- Tamper-evident ring clings to container after opening
- Minimum distance for unscrewing and resealing of cap
- Concept solution – one supplier of container and cap
- Containers produced by injection blow moulding
- Caps produced by injection moulding
- Manufactured under clean-room conditions



Europe Seal (induction seal)



SPECIFICATIONS

ref	ml	mm	mm	mm	Label mm	ref
23330	30	45	44	31	17	96038
23350/35050	50	40	71	25	42	96032
23360	60	45	64	31	37	96038
23370/35051	70	45	71	31	42	96038
23380	80	elliptical 48 x 40	76	25	56	96032
23312	120	54	84	31	52	96038
23318	185	54	112	31	80	96038

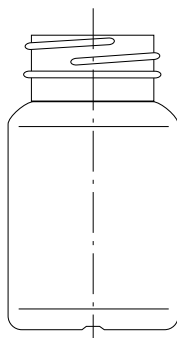
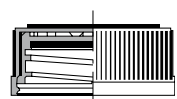

- Material: container HDPE, over closure HDPE
- Child-resistant closure with multilayer sealing pad for inductive welding
- Available aluminium membranes: standard, easy to pierce, easy to open

Triveni Round / Triveni Square (induction seal)



SPECIFICATIONS



Triveni Round

ref	ml	mm	mm	mm	CT*	CR**
DB 49	30	37	54	28	X	X
DB 07	40	38	60	33	X	X
DB 50	40	38	60	33	X	X
DB 72	50	38	69	33	X	X
DB 77	50	38	69	33	X	X
DB 05	60	40	75	33	X	X
DB 08	60	40	75	33	X	X
DB 47	60	48	59	38	X	X
DB 32	75	44	80	38	X	X
DB 09	75	41	80	38	X	X
DB 89	75	44	76	33	X	X
DB 36	75	44	80	38	X	X
DB 06	85	44	82	33	X	X
DB 69	85	44	82	33	X	X
DB 191	90	44	86	33	X	X
DB 01	100	48	78	38	X	X

*CT – continuous thread / **CR – child-resistant

Continued on next page

Triveni Round / Triveni Square (induction seal)



- Material: container HDPE, closure PP
- More than 200 standard SKU's
- Available as child-resistant
- Containers are available with thicker wall / different weight variations (low, medium, high, extra high)
- Containers are available in amber and beige colour
- FDA registered, DMF type III, DMF no. 11711 for containers, DMF no. 22377 for CT closures

Continued from previous page

DB 39	100	48	78	38	X	X
DB 10	120	47	96	38	X	X
DB 30	150	56	94	38	X	X
DB 35	150	56	94	38	X	X
DB 212	175	56	98	38	X	X
DB 130	180	55	100	45	X	X
DB 02	200	56	116	38	X	X
DB 60	200	56	116	38	X	X
DB 136	225	64	111	38	X	X
DB 11	250	67	104	53	X	X
DB 177	250	67	105	38	X	X
DB 19	300	67	121	53	X	X
DB 57	300	67	121	53	X	X
DB 20	400	76	118	53	X	X
DB 21	400	76	118	53	X	X
DB 03	500	76	145	53	X	X
DB 24	625	86	149	53	X	X
DB 33	750	86	172	53	X	X
DB 04	850	99	147	53	X	X
DB 51	950	98	165	53	X	X
DB 23	1300	99	202	53	X	X
DB 37	1500	124	174	89	X	-
DB 81	1500	124	175	53	X	X
DB 68	2000	124	214	53	X	X
DB 83	2000	124	219	110	X	-
DB 86	2500	152	174	89	X	-
DB 70	3800	152	252	110	X	-

Triveni Square

DB 200	40	30	64	28	X	X
DB 199	480	54	181	28	X	X

*CT – continuous thread / **CR – child-resistant





Triveni Dry Syrup (induction seal)



SPECIFICATIONS

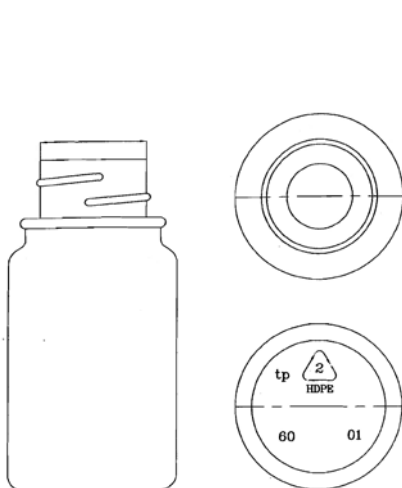

- Material: container HDPE, closure PP
- More than 25 standard SKU's
- Available as child-resistant
- Containers are available with thicker wall/different weight variations (low, medium, high)
- FDA registered, DMF type III, DMF no. 11711 for containers, DMF no. 22377 for CT closures

ref	ml	mm	mm	mm	CT*	CR**
DB 12	25	32	65	24	X	X
DB 14	60	40	79	28	X	X
DB 15	115	48	94	28	X	X
DB 87	115	48	94	28(410)	X	X
DB 27	150	49	115	28	X	X
DB 17	185	50	124	28	X	X
DB 18	225	57	125	28	X	X
DB 64	250	61	124	28	X	X
DB 171	60	40	79	28	X	X
DB 201	150	49	121	28	X	X
DB 99	185	50	124	28	X	X
DB 65	250	61	124	28	X	X
DB 75	250	61	127	28(410)	X	X
White colour						
DB 84	240	56	143	28	X	X
DB 85	480	70	175	28	X	X
Translucent						
DB 95	480	70	175	28	X	X

*CT – continuous thread / **CR – child-resistant



Triveni Black Lining (induction seal)



SPECIFICATIONS

ref	ml	mm	mm	mm	CT*	CR**
DB 169	40	38	60	33	X	X
DB 166	45	30	64	28	X	X
DB 161	60	40	75	33	X	X
DB 189	85	44	82	33	X	X
DB 170	90	43	67	38	X	X
DB 167	100	48	78	38	X	X
DB 168	150	56	94	38	X	X
DB 173	2500	152	174	89	X	-

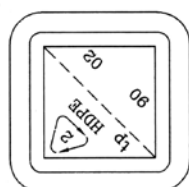
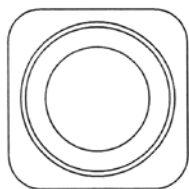

*CT – continuous thread / **CR – child-resistant

- Material: container HDPE, closure PP
- More than 10 standard SKU's
- Available as child-resistant
- Containers are available with thicker wall / different weight variations (low, high)
- FDA registered, DMF type III, DMF no. 11711 for containers, DMF no. 22377 for CT closures

Duma® Standard



SPECIFICATIONS

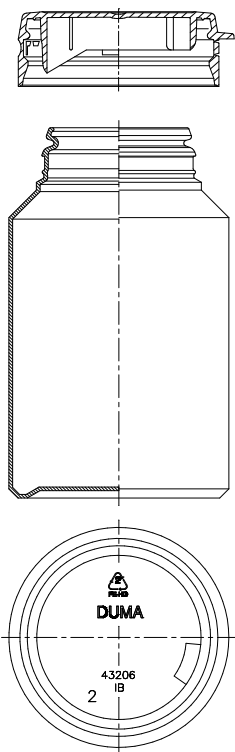



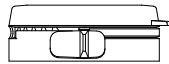
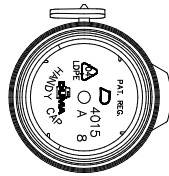



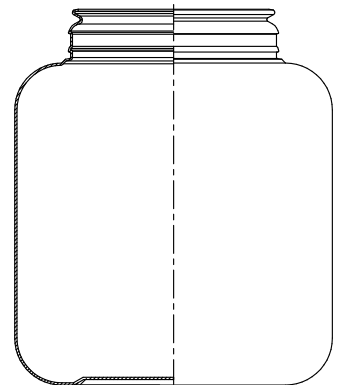
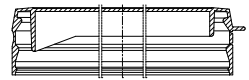
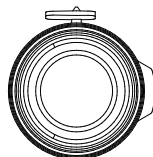

TE*



TE/Int. Des.**



Duma® Standard

							
31050	50	45	61	21	33	2813	–
31075	75	45	73	21	45	2813	–
31100	100	45	88	21	60	2813	–
43105	100	51	78	33	52	4015	4015
31125	125	45	106	21	76	2813	–
43156	150	60	84	33	55	4015	4015
43206	200	60	101	33	72	4015	4015
43307	300	69	120	33	82	4015	4015
43407	400	69	148	33	111	4015	4015
43507	500	69	176	33	139	4015	4015
952000	2000	142	168	82	100	9022	–
952500	2500	142	201	82	134	9022	–
953000	3000	142	234	82	165	9022	–

*TE – tamper-evident with break-away ring / **Int. Des – integrated desiccant

- Material: container HDPE, cap LDPE
- 13 sizes ranging from 50–3000 ml
- Snap lock system
- Narrow neck design
- Handy Cap easy-open system
- FDA registered, DMF type III, DMF no. 12077
- Tamper-evident
- Available with integrated desiccant 4 gr.
- Containers produced by injection blow moulding/blow moulding
- Caps produced by injection moulding
- Manufactured under clean-room conditions
- Caps available in various colours



Duma[®] Special



SPECIFICATIONS

TE*

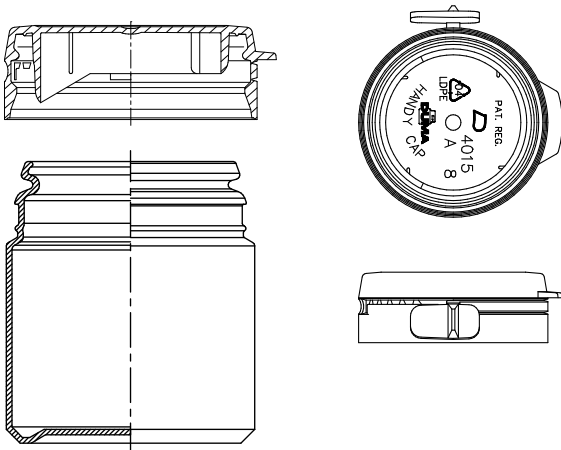

TE/Int. Des.**

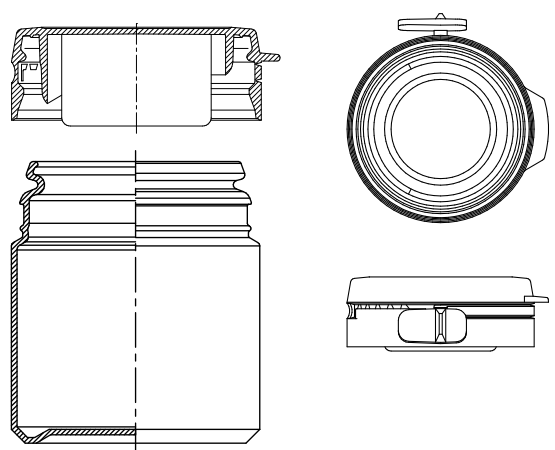

Duma® Special

ref	ml	mm	mm	mm	Label mm	ref TE*	ref TE/Int. Des.**
31030	30	36	54	21	31	2813	–
43050	50	45	51	33	32	4015	4015
43075	75	45	68	33	49	4015	4015
43100	100	45	85	33	66	4015	4015
43150	150	45	120	33	101	4015	4015
65150	150	67	70	54	44	6017	–
65250	250	67	90	54	65	6017	–
65300	300	67	113	54	88	6017	–
65400	400	67	144	54	116	6017	–
65500	500	67	177	54	151	6017	–
95500	500	100	92	82	61	9022	–
95750	750	100	124	82	93	9022	–
951000	1000	100	155	82	124	9022	–
951250	1250	100	187	82	153	9022	–
951500	1500	100	218	82	185	9022	–

*TE – tamper-evident with break-away ring / **Int. Des – integrated desiccant

- Material: container HDPE, cap LDPE
- 15 sizes ranging from 30–1500 ml
- Snap lock system
- Wide neck design
- Handy Cap easy-open system
- FDA registered, DMF type III, DMF no. 12077
- Tamper-evident
- Available with integrated desiccant 4 gr.
- Containers produced by injection blow moulding/blow moulding
- Caps produced by injection moulding
- Manufactured under clean-room conditions
- Caps available in various colours



Dudek™





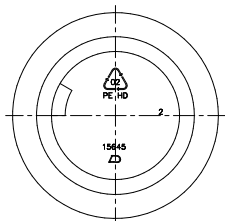
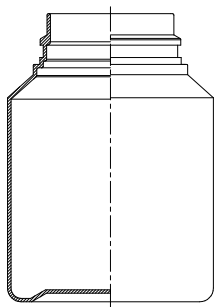

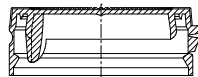
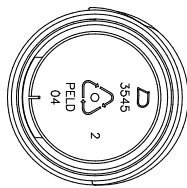

SPECIFICATIONS



TE*



Dudek™

						
1530	15	30	45	22	26	2230
3030	30	36	54	22	31	2230
5045	50	45	51	35	31	3545
07545	75	45	68	35	48	3545
10045	100	45	85	35	65	3545
12545	125	45	96	35	76	3545
15645	150	60	84	35	54	3545
15067	150	67	70	54	47	5467
25067	250	67	90	54	68	5467
30067	300	67	113	54	91	5467
40067	400	67	145	54	123	5467
50067	500	67	177	54	155	5467
50099	500	100	93	83	62	8399
75099	750	100	124	83	94	8399
100099	1000	100	156	83	125	8399
125099	1250	100	189	83	157	8399
150099	1500	100	221	83	188	8399

*TE – tamper-evident with break-away ring

- Material: container HDPE, cap LDPE
- 17 sizes ranging from 15–1500 ml
- Snap lock system
- Narrow and wide neck design
- Dudek™ cap easy-open system
- FDA registered, DMF type III, DMF no. 12077
- Tamper-evident
- Containers produced by injection blow moulding/blow moulding
- Caps produced by injection moulding
- Manufactured under clean-room conditions
- Caps available in various colours





Duma® Rectangular



SPECIFICATIONS

ref	ml	mm	mm	mm	mm	Label mm	ref TE*
653090	500	79 x 71	145	54	90	6017	
653091	1000	96 x 81	179	54	120	6017	

*TE – tamper-evident with break-away ring

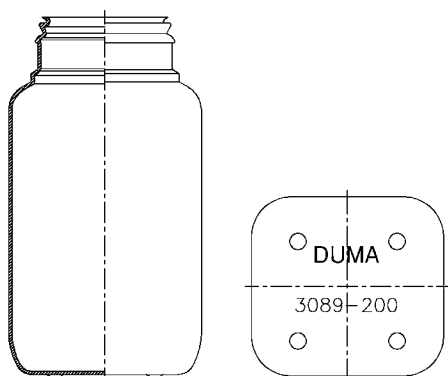

- Material: container HDPE, Duma® Handy Cap LDPE
- 2 sizes ranging from 500 – 1000 ml
- Snap lock system
- FDA registered, DMF type III, DMF no. 12077
- Tamper-evident
- Containers produced by blow moulding
- Caps produced by injection moulding
- Manufactured under clean-room conditions
- Caps available in various colours

Duma® Pocket / CR 100 / CR Box



SPECIFICATIONS

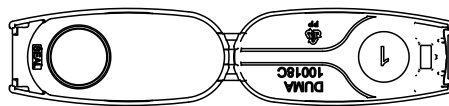

Duma® Pocket

Duma® Pocket CR 100

Duma® Pocket CR Box

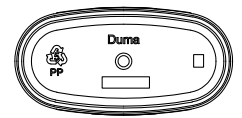
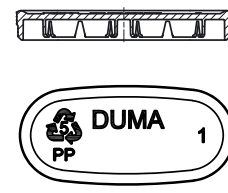
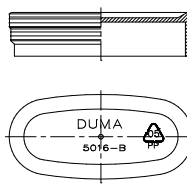
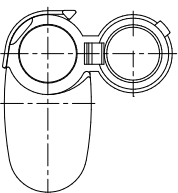
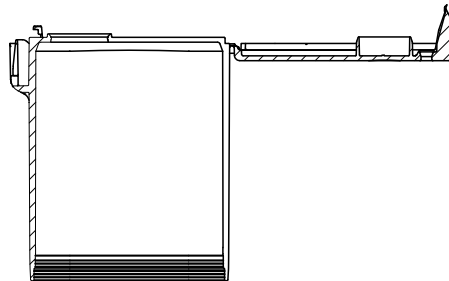
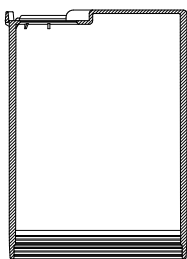
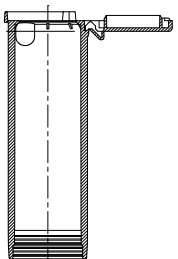



Duma® Pocket / CR 100 / CR Box



Duma® Pocket

- Material: Duma® Pocket PP, Duma® Pocket Base PP
- 2 sizes, 30 and 50 ml
- Integrated cap with visual sealing
- Oval design
- Full diameter filling via base
- FDA registered, DMF type III, DMF no. 12077
- Tamper-evident
- Produced by injection moulding
- Manufactured under clean-room conditions

3016A	30	50 x 24	50	16	39	5016B
5016A	50	50 x 24	70	16	59	5016B

TE – tamper-evident with break-away ring

Duma® Pocket CR 100

- Child-resistant feature
- Press and hold on box part by one hand and remove top by another hand
- Chose the color you like

10018C	100	70 x 31	78	–	125	10018D
--------	-----	---------	----	---	-----	--------

TE – tamper-evident / CR – child-resistant

Duma® Pocket CR Box

- Child-resistant feature
- New ergonomic design – easy to dispense
- Integrated cap with desiccant solutions

04546C	40	49,5 x 24	56	–	36	4546L
--------	----	-----------	----	---	----	-------

CR – child-resistant

GERRESHEIMER



Europe

Gerresheimer Vaerloese A/S

Walgerholm 2-8
3500 Vaerloese (Denmark)
Strandgade 87
5683 Haarby (Denmark)
Tel. +45 4477 7888

Gerresheimer Bolesławiec S.A.

ul. Bolesława Chrobrego 15
59-700 Bolesławiec (Poland)
Tel. +48 75 735 04 00

Gerresheimer Zaragoza, S.A.

P.I. Valdemuel
Camino del Sabinar, s/n
50290 Epila, Zaragoza (Spain)
Tel. +34 976 817 408

South America

Gerresheimer Plásticos São Paulo Ltda

Rodovia Raposo Tavares 25.599 – Km 25,6
06708-000 Cotia, São Paulo (Brazil)
Tel. +55 11 4613 1000

Gerresheimer Plásticos São Paulo Ltda

Rua da Congregaçãõ 56
06816-902 Embu, São Paulo (Brazil)
Tel. +55 11 2133 1212

Gerresheimer Buenos Aires S.A.

Mercedes 2153
C1417AUA Buenos Aires (Argentina)
Tel. +54 11 4639 0771

Gerresheimer Plásticos São Paulo Ltda

Rua Mario Regalo Pereira, Nr. 160 and 170
05550-060 Butantã, São Paulo (Brazil)
Tel. +55 11 3783 83 50

Gerresheimer Plásticos São Paulo Ltda

VP 3 E S/N. Qd 06 A Módulo 02
Barreiro do Meio – Distrito Agroindustrial
75132-100 Anápolis (Brazil)
Tel. +55 62 3142-2555

Asia

Triveni Polymers Pvt. Ltd.

Kundli Plant, Haryana
G.T. Road, Piao Maniyari
Kundli-131028 Distt. Sonapat
Haryana (India)
Tel. +91-130-2219070

Headquarters New Delhi
Regd. Office 2-B, DCM Building
Barakhamba Road, Connaught Place
New Delhi-110001 (India)
Tel. +91-130-2219070

Gerresheimer Singapore Pte. Ltd.

1 Harbourfront Place
Harbourfront Tower One
Unit #04-01
Singapore 098633
Tel. +65 6722 3781

More information: Info-plasticpackaging@gerresheimer.com

www.gerresheimer.com

Pharmaceutical Plastic Packaging and Systems for South America is to be found in a separate catalogue